

## Operating manual

Barometric transmitter

### HD9408.3B



Companies / Brands of GHM

Members of GHM GROUP:

**GREISINGER**

**HONSBERG**

**Martens**

**IMTRON**

**Delta OHM**

**VAL.CO**

[www.deltaohm.com](http://www.deltaohm.com)

Keep for future reference.

# TABLE OF CONTENTS

<b>1</b>	<b>INTRODUCTION</b> .....	<b>3</b>
<b>2</b>	<b>DESCRIPTION</b> .....	<b>4</b>
<b>3</b>	<b>INSTALLATION</b> .....	<b>5</b>
3.1	ELECTRICAL CONNECTIONS OF THE MODELS HD9408.3B.1 AND HD9408.3B.2 .....	5
3.1.1	RS485 CONNECTION .....	5
3.1.2	RS422 CONNECTION .....	6
3.1.3	RS232 CONNECTION .....	7
3.1.4	CONNECTION OF THE ANALOG OUTPUT .....	7
3.2	ELECTRICAL CONNECTIONS OF THE MODEL HD9408.3B.3 .....	8
3.2.1	SDI-12 CONNECTION.....	8
<b>4</b>	<b>CONFIGURATION</b> .....	<b>9</b>
4.1	CHOOSING THE DIGITAL OUTPUT TYPE IN HD9408.3B.1 AND HD9408.3B.2 MODELS .....	9
4.2	CHOOSING THE PROTOCOL IN HD9408.3B.1 AND HD9408.3B.2 MODELS .....	9
4.3	SELECTING THE UNIT OF MEASUREMENT .....	10
4.4	CONFIGURING THE ANALOG OUTPUT .....	10
4.5	SERIAL COMMANDS OF DELTA OHM PROTOCOL FOR HD9408.3B.1 AND HD9408.3B.2 .....	11
4.6	SERIAL COMMANDS OF DELTA OHM PROTOCOL FOR HD9408.3B.3.....	14
<b>5</b>	<b>MODBUS-RTU PROTOCOL</b> .....	<b>17</b>
5.1	MEASUREMENTS READING .....	17
5.2	SETTING THE MODBUS PARAMETERS .....	17
5.3	CONFIGURATION REGISTER.....	19
5.4	ERROR REGISTER .....	19
<b>6</b>	<b>NMEA PROTOCOL</b> .....	<b>20</b>
<b>7</b>	<b>SDI-12 PROTOCOL</b> .....	<b>21</b>
<b>8</b>	<b>TECHNICAL SPECIFICATIONS</b> .....	<b>26</b>
<b>9</b>	<b>INSTRUMENT STORAGE</b> .....	<b>28</b>
<b>10</b>	<b>SAFETY INSTRUCTIONS</b> .....	<b>28</b>
<b>11</b>	<b>ORDERING CODES</b> .....	<b>29</b>

# 1 INTRODUCTION

HD9408.3B is a barometric transmitter that uses a piezoresistive high accuracy and temperature-compensated sensor. It allows measuring the atmospheric pressure in the range 0...1350 hPa (digital outputs) or 500...1200 hPa (analog outputs), providing extreme accuracy and time stability, with excellent repeatability, low hysteresis, and excellent temperature behavior.

The superior performances are obtained thanks to the employment of a piezoresistive Silicon sensor that integrates both a pressure sensitive as well as a temperature sensitive element. The measurement of pressure and temperature are processed by a microprocessor to obtain an output signal that is compensated over the transmitter's whole, wide temperature operating range: -40...+85°C.

The sensor is factory calibrated at several points at different temperatures in the range of use.

The transmitter is available in three versions which differ in the output type:

- **HD9408.3B.1:** configurable 0...5 V or 1...5 V analogue voltage output and digital RS232, RS422 or RS485 output. Standard MODBUS-RTU and NMEA 0183 protocols.
- **HD9408.3B.2:** active configurable 0...20 mA or 4...20 mA current output and digital RS232, RS422 or RS485 output. Standard MODBUS-RTU and NMEA 0183 protocols.
- **HD9408.3B.3:** digital SDI-12 output, compatible with version 1.3 of the protocol.

The digital output enables the transmission of the measurements over long distances and connects the transmitter to sensor networks.

The pressure measured and transmitted with MODBUS RTU and SDI-12 protocols can be expressed in different user-selectable measuring units.

The watertight housing with **IP 67** protection degree allows the use of the instrument even in harsh environments.

The instrument is particularly suitable for meteorological applications (AWOS - Automated Weather Observing Systems), environmental monitoring systems, meteorological and environmental data logging, measurement laboratories, atmospheric pressure compensation in the performance of internal combustion engines, barometric pressure compensation in clean rooms, vehicle emission test.

Its low power consumption makes it ideal for remote acquisition systems such as automatic weather stations powered by solar cells.

DC power supply 10...30 Vdc.

## 2 DESCRIPTION



1. Housing mounting holes.
2. M12 connector for power supply and outputs.
3. Barometric pressure input.

## 3 INSTALLATION

The sensor and electronics are housed in a sturdy metal housing with IP 67 degree of protection. The transmitter can be mounted in any position, but typically is attached to a vertical wall with the outlet pressure facing downward. The two holes on the housing's sides allow you to secure the base of the transmitter directly to a panel or a wall. See the chapter "TECHNICAL SPECIFICATIONS" for the dimensions of the mounting holes.

### 3.1 ELECTRICAL CONNECTIONS OF THE MODELS HD9408.3B.1 AND HD9408.3B.2

The transmitters HD9408.3B.1 and HD9408.3B.2 have an 8-pole M12 male connector. **On request, CP18... cables with 8-pole M12 female connector are available.**

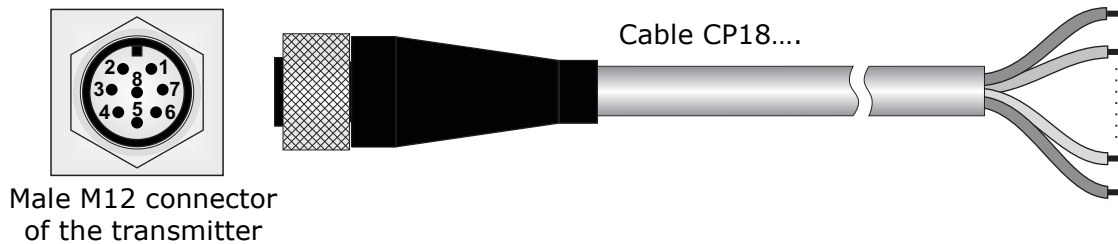

**Fig. 3.1.1: cable CP18...**

**TAB. 3.1.1: connections of HD9408.3B.1 and HD9408.3B.2**

Connector pin N°	Function		CP18... cable wire N°/colour
	Symbol	Description	
1	PWR-	Power Negative / serial grounding	12/Black + 7/Violet + 6/Pink (*)
2	PWR+	Power Positive	1/Red + 2/Blue + 4/Grey-Pink (*)
3	RX-	Rx- for RS422	3/Yellow
4	TX-	Tx for RS232/ Tx- for RS422 DATA- for RS485	9/White
5	TX+	Tx+ for RS422 / DATA+ for RS485	5/Red-Blue
6	RX+	Rx for RS232/ Rx+ for RS422	8/Grey
7	AGND	Analog output Negative	10/Brown
8	AOUT	Analog output Positive	11/Green

(\*) Wires shorted on the connector pin.

#### 3.1.1 RS485 CONNECTION

The RS485 connection of the transmitter is made over a screened twisted-pair cable for the signals and a third grounding wire.

At the beginning and at the end of each segment you should apply the line terminator.

The maximum number of devices that can be connected to the (Bus) line 485 depends on the load characteristics of the devices to be connected. The RS485 standard requires that the total load does not exceed 32 unit loads. The load of a transmitter is equal to 1 unit load. If the total load is greater than 32 unit loads, divide the network into segments and then put a signal repeater between a segment and the next. At the beginning and end of each segment of the line, terminations should be applied. The RS485 output of the transmitter is not isolated.

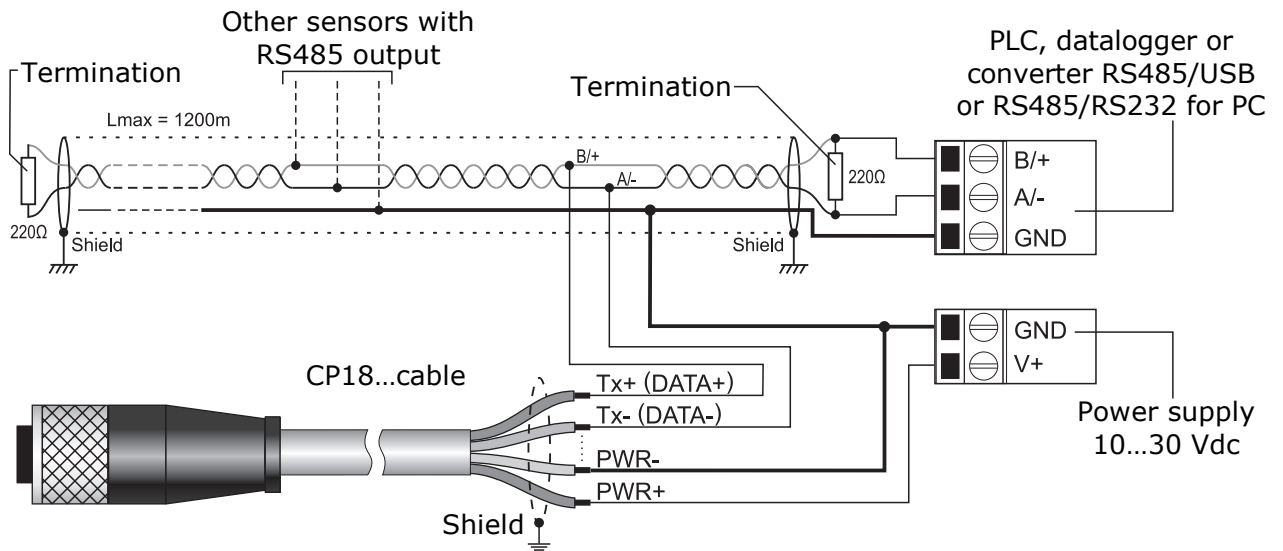

**Fig. 3.1.2: RS485 output connection**

The cable maximum length depends on baud rate and cable characteristics. Typically, the maximum length is 1200m. The data line must be kept separated from any power lines in order to prevent interferences on the transmitted signal.

Each transmitter placed on the network is univocally identified by an address. **Transmitters having the same address shall not be present in the network.**

NMEA, MODBUS-RTU and Delta OHM proprietary protocols can be used with RS485 connection. Before connecting the instrument to the network, configure address and Baud Rate (see paragraph 4.5).

### 3.1.2 RS422 CONNECTION

The RS422 standard is used for the point-to-point connection over long distances. The instrument is connected to the PC by means of a screened cable with two twisted-pair cables for the signals and an additional wire for grounding. It is necessary to provide for line terminations at the ends of the connections.

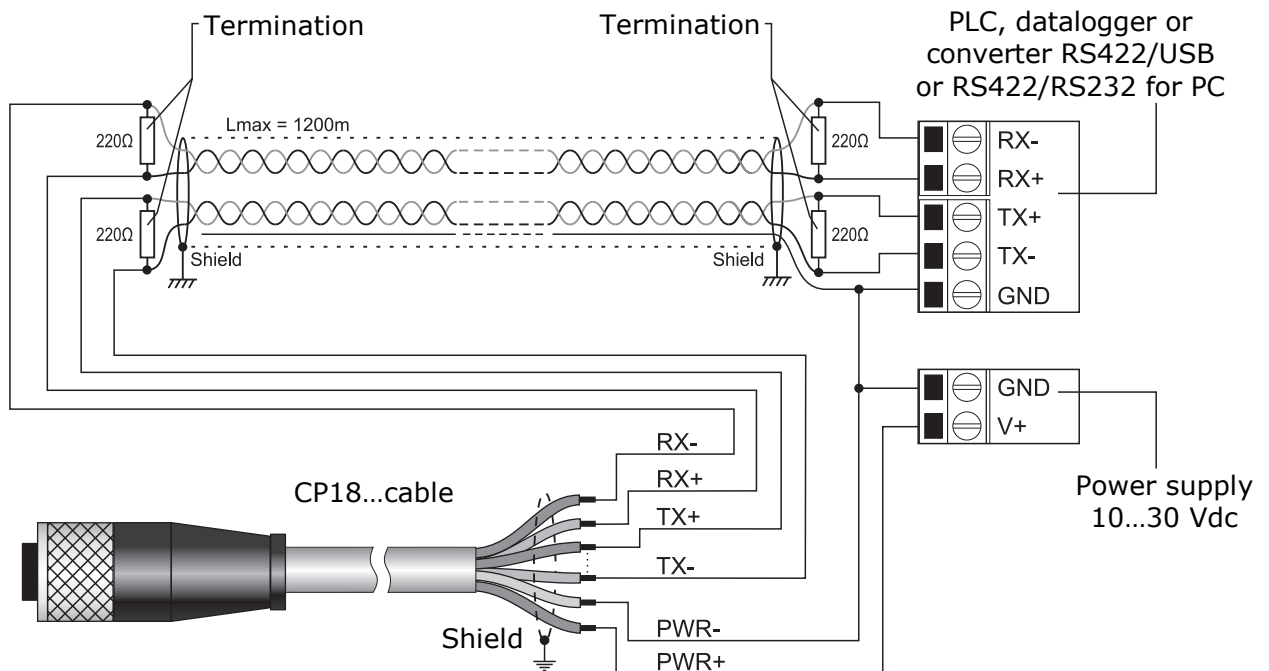

**Fig. 3.1.3: RS422 connection**

The cable maximum length depends on baud rate and cable characteristics. Typically, the maximum length is 1200m. The data line must be kept separated from any power lines in order to prevent interferences on the transmitted signal.

NMEA, MODBUS-RTU and Delta OHM proprietary protocols can be used with RS422 connection. Before connecting the instrument to the network, configure address and Baud Rate (see paragraph 4.5).

### 3.1.3 RS232 CONNECTION

The length of RS232 cables should not exceed 15 m. If the PC is not fitted with RS232 serial ports, it is possible to interpose the adapter cable **RS52** (optional) between instrument and PC, which has an integrated USB/RS232 converter.

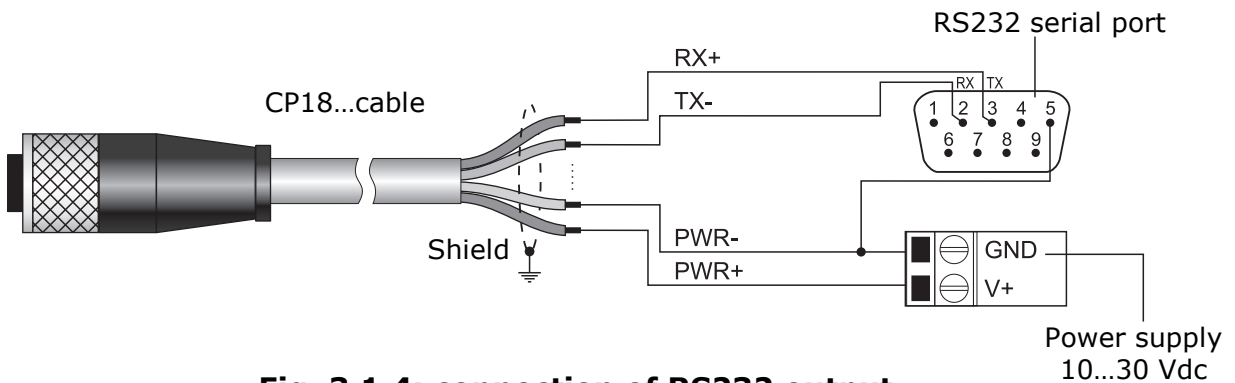

**Fig. 3.1.4: connection of RS232 output**

NMEA and Delta OHM proprietary protocols can be used with RS232 connection.

### 3.1.4 CONNECTION OF THE ANALOG OUTPUT

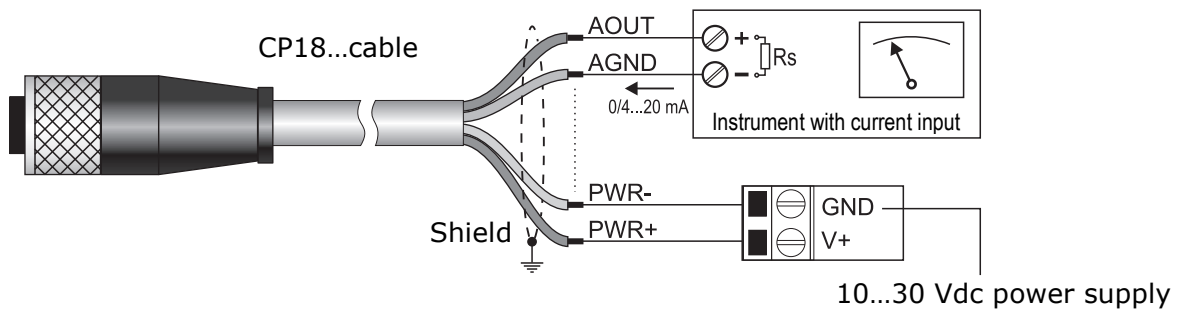

**Fig. 3.1.5: connection of the active 0...20/4...20 mA analog output**

In case of analog current output, the maximum shunt resistance  $R_s$  of the receiver depends on the power supply:  $R_s \leq 100 \Omega @ 12V$ ,  $R_s \leq 700 \Omega @ 24V$ .

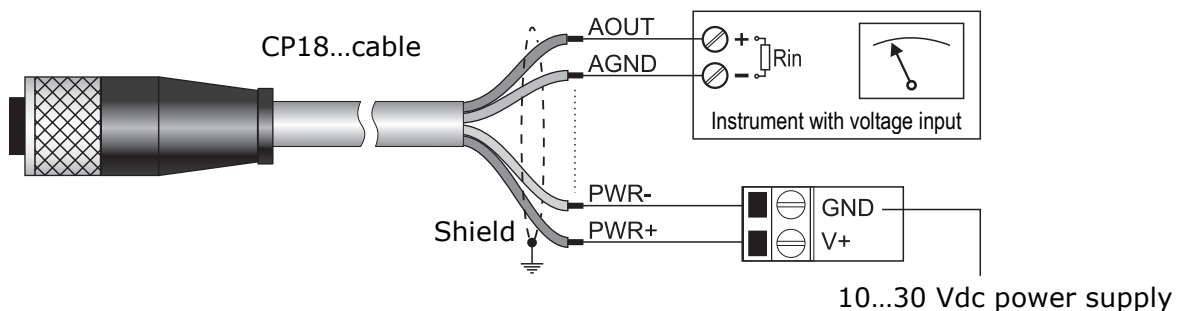
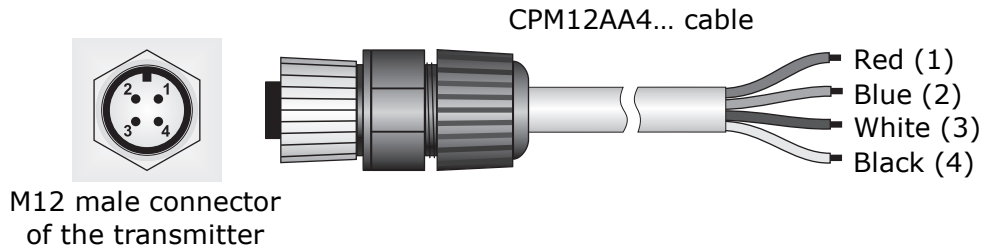

**Fig. 3.1.6: connection of analog 0...5/1...5 V voltage output**

In case of analog voltage output, the input resistance  $R_{in}$  of the receiver should be at least 100 k $\Omega$ .

### 3.2 ELECTRICAL CONNECTIONS OF THE MODEL HD9408.3B.3

The transmitter HD9408.3B.3 has a 4-pole M12 male connector. **On request, CPM12AA4... cables with 4-pole M12 connector are available.**



**Fig. 3.2.1: CPM12AA4... cable**

**TAB. 3.2.1: connections of HD9408.3B.3**

Connector numbering	Function		Color
	Symbol	Description	
1	PWR+	Power Positive	Red
2	PWR-	Power Negative / serial grounding	Blue
3	SDI	SDI-12 data line	White
4		Screen	Black

#### 3.2.1 SDI-12 CONNECTION

More SDI-12 sensors can be connected in parallel. The distance between a sensor and the acquisition system should not exceed 60 m. Before connecting the instrument to an SDI-12 network containing other sensors, set the address by using the proper SDI-12 command (see chapter 7).

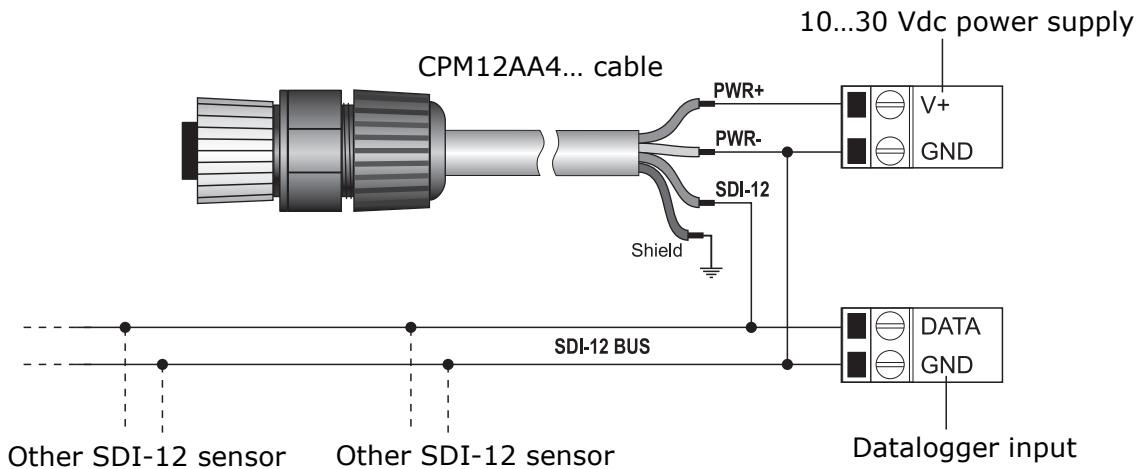

**Fig. 3.2.2: SDI-12 connection**



## 4 CONFIGURATION

When powered, the transmitter always starts to operate with the set operating protocol. The models HD9408.3B.1 and HD9408.3B.2 are factory set with MODBUS-RTU protocol, RS485 physical interface, Baud Rate 19200 and communication parameters 8E1. To change the settings of the transmitter, see the next paragraphs.

### 4.1 CHOOSING THE DIGITAL OUTPUT TYPE IN HD9408.3B.1 AND HD9408.3B.2 MODELS

The models HD9408.3B.1 and HD9408.3B.2 allow selecting the type of digital output (RS232, RS422 or RS485) on hardware level, by means of dip switches on the electronic board, or at software level, by means of an appropriate serial command. By default, the RS485 output via the dip switches is set. To access the dip switches, unscrew the screws fixing the housing cover, remove the cover and set the dip switches as shown in figure 4.1.1.

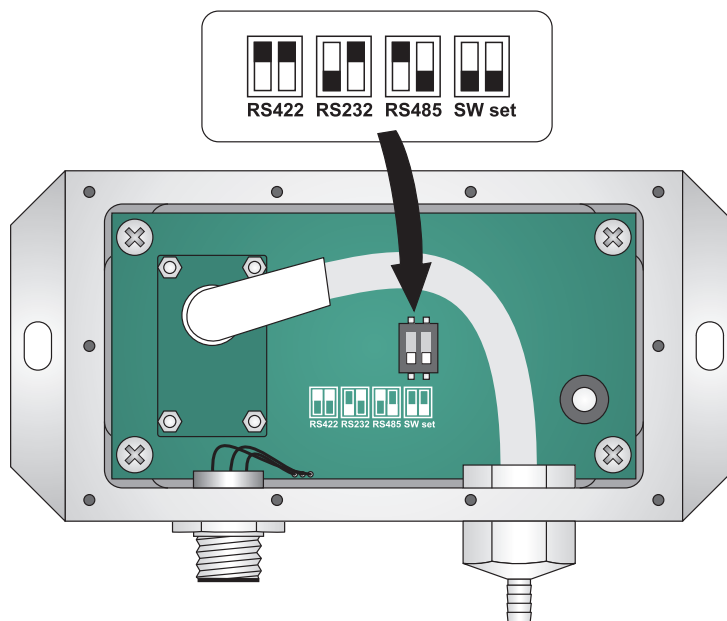

**Fig. 4.1.1: selecting the digital output by means of the dip switches**

The setting via the dip switches has priority over the setting via serial command. By selecting the option "**SW set**", the transmitter uses the digital output set at software level with the serial command **CPI** described in paragraph 4.5.

### 4.2 CHOOSING THE PROTOCOL IN HD9408.3B.1 AND HD9408.3B.2 MODELS

In the models HD9408.3B.1 and HD9408.3B.2, NMEA 0183 and MODBUS-RTU standard protocols and Delta OHM proprietary protocol are available. The selection of the protocol is done via the serial command **CPI** described in paragraph 4.5. If the transmitter digital output is set by means of the dip switches, the choice of the protocol must be compatible with the selected physical interface, as reported in table 4.2.1. By default, the MODBUS-RTU protocol with RS485 physical interface is set.

**TAB. 4.2.1: compatibility of physical interface/protocols in models HD9408.3B.1 and HD9408.3B.2**

		Physical Interface		
		RS232	RS422	RS485
Protocol	Delta OHM Proprietary	✓	✓	✓
	MODBUS-RTU		✓	✓
	NMEA 0183	✓	✓	✓

### 4.3 SELECTING THE UNIT OF MEASUREMENT

The pressure measured and transmitted via the digital output with MODBUS-RTU and SDI-12 standard protocols can be expressed in a user selectable unit of measurement among: Pa, hPa, kPa, mbar, bar, atm, psi, mmHg, inHg, mmH<sub>2</sub>O, ftH<sub>2</sub>O, kg/cm<sup>2</sup>, Torr. The default unit is hPa. The unit setting is done with the serial command **CPU** described in paragraph 4.5. Table 4.3.1 shows the resolution of the measurement as a function of the selected unit.

**TAB. 4.3.1: measuring unit and resolution with Modbus and SDI-12 protocols**

Unit of measurement	Resolution
Pa	1 Pa
hPa	0.01 hPa
kPa	0.001 kPa
mbar	0.01 mbar
bar	0.00001 bar
atm	0.00001 atm
psi	0.0001 psi
mmHg	0.001 mmHg
inHg	0.0001 inHg
mmH <sub>2</sub> O	0.1 mmH <sub>2</sub> O
ftH <sub>2</sub> O	0.0001 ftH <sub>2</sub> O
kg/cm <sup>2</sup>	0.00001 kg/cm <sup>2</sup>
Torr	0.001 Torr

With the NMEA 0183 standard protocol, the pressure value is transmitted in two fixed units: **Pa** and **bar**. With the Delta OHM proprietary protocol, the pressure is transmitted in the fixed units **mbar**, **psi** and **hPa**.

### 4.4 CONFIGURING THE ANALOG OUTPUT

The analog output in the models HD9408.3B.1 and HD9408.3B.2 is factory preset to have the output signal corresponding to the 500...1200 hPa measuring range. The analog output can be configured so as to have the output signal corresponding to a different measuring range by using the serial commands **CAI** (sets the initial value of the measuring interval) and **CAF** (sets the final value of the measuring interval).

To reverse the operation of the analog output, so that the output signal decreases as the measured pressure increases, use the serial command **CAiE**. To cancel the inversion and restore the output normal operation, use the serial command **CAiD**.

To add or remove an offset to the minimum value of the output signal, so that to pass from the range 0...5 V or 0...20 mA to the range 1...5 V or 4...20 mA and vice versa, use the serial commands **CAOE** (adds the offset) and **CAOD** (remove the offset). The default mode is with offset.

The details on the use of the serial commands are described in paragraph 4.5.

#### **4.5 SERIAL COMMANDS OF DELTA OHM PROTOCOL FOR HD9408.3B.1 AND HD9408.3B.2**

All the operating parameters can be set by connecting the transmitter to the PC and sending, via a standard serial communication program, the serial commands of the Delta OHM proprietary protocol.

The Delta OHM proprietary protocol can be used with RS232, RS485 and RS422 digital outputs. If the RS232 output is used and the PC has only USB ports, place between the PC and the instrument a RS232/USB converter. If the RS422 or RS485 digital output is used, place between the PC and the instrument a converter from RS422 or RS485 to RS232 or USB. For the wiring diagrams, see chapter "INSTALLATION".

**If a USB converter is used, it is necessary to install the relevant USB drivers in the PC.**

**NOTES ON THE INSTALLATION OF UNSIGNED USB DRIVER:** before installing unsigned USB driver into operating systems starting from Windows 7, it is necessary to restart the PC by disabling the driver signing request. If the operating system is 64-bit, even after installation the request of driver signing have to be disabled each time the PC is restarted.

#### **PROCEDURE FOR SETTING THE PARAMETERS:**

- 1.** Connect the transmitter to the PC according to the selected digital output (the factory-set digital output is RS485) and power the transmitter. The transmitter always starts to operate with the set operating protocol.
- 2.** Start a serial communication program, as Hyperterminal for instance. In the program, set the COM port number to which the transmitter is connecting and set the communication parameters the same as those of the protocol currently operating in the instrument: "57600 8N2" for proprietary protocol, "19200 8E1" for MODBUS - RTU (default settings, the MODBUS -RTU parameters are configurable), "4800 8N1" for NMEA.
- 3.** If the set operating protocol is different from the Delta OHM proprietary protocol (the factory-set protocol is MODBUS-RTU), send the command **|||** (sequence of three 124 decimal code ASCII characters followed by the Enter key). The transmitter replies with the sequence **&|**.
- 4.** Within 10 seconds from the previous command, send the command **@** (64 decimal code ASCII character followed by the Enter key) to confirm the switch to the Delta OHM proprietary protocol. The transmitter replies with the sequence **&|**. Switching to the Delta OHM proprietary protocol, the previous communication parameters (baud rate, data bits, parity and stop bits) are maintained.  
Note: if the transmitter does not receive the command **@** within 10 seconds from the command **|||**, the previous protocol is automatically restored.
- 5.** Send the command **CAL USER ON**.

Note: the command CAL USER ON is disabled after 5 minutes of inactivity. The command is necessary only for the configuration writing commands, it is not necessary for the configuration reading commands.

6. Send the serial commands reported in table 4.5.1 to configure the transmitter or read the current settings.
7. To go back to the operating protocol, send the command # (35 decimal code ASCII character followed by the Enter key) or power cycle the instrument.

**TAB. 4.5.1: serial commands for HD9408.3B.1 and HD9408.3B.2**

Command	Reply	Description
<b>Instrument general information</b>		
<b>P0</b>	&	Ping
<b>G0</b>	<i>Model</i>	Instrument model
<b>G2</b>	SN= <i>number</i>	Serial number
<b>G3</b>	Firm.Ver.= <i>version</i>	Firmware version
<b>G4</b>	Firm.Date= <i>date</i>	Firmware date (yyyy/mm/dd)
<b>GD</b>	F cal: <i>date and time</i>	Date of factory calibration (yyyy/mm/dd hh:mm:ss)
<b>Measurements request</b>		
<b>S0</b>	& ###.##C (or F) ####.####mbar ###.####psi /F ####.##hPa	Last temperature (in °C or °F, accuracy ±1 °C) and pressure (in mbar, psi and hPa) value measured. The parameter "/F" that appears in the reply is reserved.
<b>S1</b>	& ###.##C (or F) ####.####mbar ###.####psi /F ####.##hPa	Continuous sending, once per second, of the last temperature (in °C or °F, accuracy ±1 °C) and pressure (in mbar, psi and hPa) value measured. The parameter "/F" that appears in the reply is reserved.
<b>Configuration of physical interface and protocol</b>		
<b>CPIIn</b>	&	Sets the physical interface and the protocol: n= <b>0</b> ⇒ RS485 with MODBUS-RTU protocol n= <b>1</b> ⇒ RS422 with MODBUS-RTU protocol n= <b>2</b> ⇒ RS232 with NMEA 0183 protocol n= <b>3</b> ⇒ RS485 with NMEA 0183 protocol n= <b>4</b> ⇒ RS422 with NMEA 0183 protocol n= <b>5</b> ⇒ RS232 with Delta OHM proprietary protocol n= <b>6</b> ⇒ RS485 with Delta OHM proprietary protocol n= <b>7</b> ⇒ RS422 with Delta OHM proprietary protocol Preset to 0 ⇒ RS485 with MODBUS-RTU protocol.  <i>Note 1:</i> if the physical interface is set via hardware with the dip switches, only the commands setting a physical interface equal to that set via hardware are accepted.  <i>Note 2:</i> if the dip switches are set to "SW set", the command is always accepted, even if an interface different from the current physical connection is set (in such a case you will need to change the connections according to the new interface set in order to communicate again with the instrument).
<b>RAP</b>	& n	Reads the setting of physical interface and protocol (see the command CPUIn for the meaning of the value n).

Command	Reply	Description
<b>Configuration of units of measurement</b>		
<b>CPTx</b>	&	Sets the temperature unit of measurement read with the MODBUS and SDI-12 protocols: x= <b>C</b> ⇒ °C, x= <b>F</b> ⇒ °F Preset to C ⇒ °C
<b>RAT</b>	& <i>unit of measurement</i>	Reads the temperature unit of measurement set for the MODBUS and SDI-12 protocols.
<b>CPUn</b>	&	Sets the pressure unit of measurement read with the MODBUS and SDI-12 protocols: n= <b>0</b> ⇒ Torr, n= <b>1</b> ⇒ Pa, n= <b>2</b> ⇒ hPa, n= <b>3</b> ⇒ kPa n= <b>4</b> ⇒ mbar, n= <b>5</b> ⇒ psi, n= <b>6</b> ⇒ kg/cm <sup>2</sup> , n= <b>7</b> ⇒ mmH <sub>2</sub> O n= <b>8</b> ⇒ mmHg, n= <b>9</b> ⇒ inHg, n= <b>A</b> ⇒ atm, n= <b>B</b> ⇒ bar n= <b>C</b> ⇒ ftH <sub>2</sub> O Preset to 2 ⇒ hPa
<b>RAU</b>	& n F	Reads the pressure unit of measurement set for MODBUS and SDI-12 protocols. See command CPUn for the unit of measurement corresponding to the value n. "F" is a reserved parameter.
<b>Configuration of MODBUS-RTU parameters</b>		
<b>CMAnnn</b>	&	Sets the Modbus address to nnn (1...247). Preset to 1.
<b>RMA</b>	& nnn	Reads the Modbus address.
<b>CMBn</b>	&	Sets the Modbus Baud Rate: n= <b>0</b> ⇒ 9600, n= <b>1</b> ⇒ 19200. Preset to 1 ⇒ 19200
<b>RMB</b>	& n	Reads the Modbus Baud Rate: n=0 ⇒ 9600, n=1 ⇒ 19200
<b>CMPn</b>	&	Sets the Modbus transmission mode: n= <b>0</b> ⇒ 8N1, n= <b>1</b> ⇒ 8N2, n= <b>2</b> ⇒ 8E1 n= <b>3</b> ⇒ 8E2, n= <b>4</b> ⇒ 8O1, n= <b>5</b> ⇒ 8O2 Preset to 2 ⇒ 8-E-1 Note: N=no parity, E=even parity, O=odd parity
<b>RMP</b>	& n	Reads the Modbus transmission mode (see the command CMPn for the mode corresponding to the value n).
<b>CMWn</b>	&	Sets the receiving mode after the Modbus transmission: n= <b>0</b> ⇒ Violate protocol and go in Rx mode right after Tx n= <b>1</b> ⇒ Respect protocol and wait for 3.5 characters after Tx Preset to 1 ⇒ Respect the protocol.
<b>RMW</b>	& n	Reads the receiving mode after the Modbus transmission (see the command CMWn for the mode corresponding to the value n):
<b>Configuration of NMEA 0183 parameters</b>		
<b>CPDnnnn</b>	&	Sets the sending interval of the string with the measurements in NMEA mode to nnnn seconds. The interval must be between 1 and 3600 seconds. Preset to 1 second.
<b>RN</b>	& nnnn	Reads the setting of the sending interval of the string with the measurements in NMEA mode.

Command	Reply	Description
<b>Configuration of analog output</b>		
<b>CAInnnnn</b>	&	Associates the initial scale of the analog output to the pressure value nnnnn expressed in tenth of hPa. The parameter must be between zero and the pressure value associated to the analog output full scale. Preset to 5000 (=500.0 hPa).
<b>RAI</b>	& nnnnn	Reads the value corresponding to the initial scale of the analog output.
<b>CAFnnnnn</b>	&	Associates the full scale of the analog output to the pressure value nnnnn expressed in tenth of hPa. The parameter must be between the pressure value associated to the initial scale of the analog output and 12000 (=1200.0 hPa). Preset to 12000.
<b>RAF</b>	& nnnnn	Reads the value corresponding to the full scale of the analog output.
<b>CAOE</b>	&	Adds the offset to the analog output (1...5 V or 4...20 mA).
<b>CAOD</b>	&	Remove the offset from the analog output (0...5 V or 0...20 mA).
<b>RAO</b>	& n	Reads the setting of the offset for the analog output: n=0 ⇒ senza offset, n=1 ⇒ con offset
<b>CAiE</b>	&	Reverses the direction of the analog output: 5...0 V, 5...1 V, 20...4 mA, 20...0 mA.
<b>CAiD</b>	&	Cancel the inversion of the direction of the analog output.
<b>RAi</b>	& n	Reads the setting of the direction of the analog output: n=0 ⇒ normal, n=1 ⇒ reversed
<b>Setting of sensor offset</b>		
<b>CAXnnnn</b>	&	Adds the offset nnnn, expressed in hundredths of hPa, to the measured pressure value. The parameter must be between -1000 (= -10.00 hPa) and +1000 (= +10.00 hPa). For positive values, always indicate also the + sign. Preset to 0.
<b>RAX</b>	& ##.##	Reads the offset set for the pressure measurement.

#### 4.6 SERIAL COMMANDS OF DELTA OHM PROTOCOL FOR HD9408.3B.3

In the model HD9408.3B, the operating parameters can be set in two ways:

- directly with the SDI-12 protocol, via the extended commands described in chapter 7;
- by connecting the transmitter to the PC through a converter from SDI-12 to RS232 or USB, and by sending, via a standard serial communication program, the serial commands of the Delta OHM proprietary protocol.

**If a USB converter is used, it is necessary to install the relevant USB drivers in the PC.**

**NOTES ON THE INSTALLATION OF UNSIGNED USB DRIVER:** before installing unsigned USB driver into operating systems starting from Windows 7, it is necessary to restart the PC by disabling the driver signing request. If the operating system is 64-bit, even after installation the request of driver signing have to be disabled each time the PC is restarted.

**PROCEDURE FOR SETTING THE PARAMETERS BY MEANS OF THE DELTA OHM PROTOCOL:**

1. Connect the transmitter to the PC (connect only one transmitter at a time) and power the transmitter. The transmitter always starts to operate with the SDI-12 protocol.
2. Start a serial communication program, as Hyperterminal for instance. Set the following communication parameters:  
 baud rate: 1200    data bits: 7,    parity: Even,    stop bits: 1  
 In the program, set the COM port number to which the transmitter is connecting.
3. Send the command **aXf\_int\_424!** where **a** is the address of the transmitter (default 0). The transmitter replies with **fm activated!**.
4. Change the settings of the serial communication program as follows:  
 baud rate: 57600    data bits: 8,    parity: Even,    stop bits: 2
5. Send the command **CAL USER ON**.  
 Note: the command CAL USER ON is disabled after 5 minutes of inactivity. The command is necessary only for the configuration writing commands, it is not necessary for the configuration reading commands.
6. Send the serial commands reported in table 4.6.1 to configure the transmitter or read the current settings.
7. To go back to the operating protocol, power cycle the instrument.

**TAB. 4.6.1: serial commands for HD9408.3B.3**

	Reply	Description
<b>Instrument general information</b>		
<b>G0</b>	a:Model	Instrument model
<b>G2</b>	a:SN=number	Serial number
<b>G3</b>	a:Firm.Ver.=version	Firmware version
<b>G4</b>	a:Firm.Date=date	Firmware date (yyyy/mm/dd)
<b>GD</b>	a:F cal:date and time	Date of factory calibration (yyyy/mm/dd hh:mm:ss)
<b>Measurements request</b>		
<b>S0</b>	& ###.##C (or F) #####mbar ###.####psi /F #####hPa	Last temperature (in °C or °F, accuracy ±1 °C) and pressure (in mbar, psi and hPa) value measured. The parameter "/F" that appears in the reply is reserved.
<b>S1</b>	& ###.##C (or F) #####mbar ###.####psi /F #####hPa	Continuous sending, once per second, of the last temperature (in °C or °F, accuracy ±1 °C) and pressure (in mbar, psi and hPa) value measured. The parameter "/F" that appears in the reply is reserved.
<b>Configuration of units of measurement</b>		
<b>CPTx</b>	&	Sets the temperature unit of measurement read with the MODBUS and SDI-12 protocols: x=C ⇒ °C, x=F ⇒ °F Preset to C ⇒ °C
<b>RAT</b>	& unità di misura	Reads the temperature unit of measurement set for the MODBUS and SDI-12 protocols.

	<b>Reply</b>	<b>Description</b>
<b>CPUn</b>	&	<p>Sets the pressure unit of measurement read with the MODBUS and SDI-12 protocols:</p> <p>n=<b>0</b> ⇒ Torr, n=<b>1</b> ⇒ Pa, n=<b>2</b> ⇒ hPa, n=<b>3</b> ⇒ kPa  n=<b>4</b> ⇒ mbar, n=<b>5</b> ⇒ psi, n=<b>6</b> ⇒ kg/cm<sup>2</sup>, n=<b>7</b> ⇒ mmH<sub>2</sub>O  n=<b>8</b> ⇒ mmHg, n=<b>9</b> ⇒ inHg, n=<b>A</b> ⇒ atm, n=<b>B</b> ⇒ bar  n=<b>C</b> ⇒ ftH<sub>2</sub>O</p> <p>Preset to 2 ⇒ hPa</p>
<b>RAU</b>	& n F	<p>Reads the pressure unit of measurement set for MODBUS and SDI-12 protocols. See command CPUn for the unit of measurement corresponding to the value n. "F" is a reserved parameter.</p>
<b>Setting of sensor offset</b>		
<b>CAXnnnn</b>	&	<p>Adds the offset nnnn, expressed in hundredths of hPa, to the measured pressure value.</p> <p>The parameter must be between -1000 (= -10.00 hPa) and +1000 (= +10.00 hPa). For positive values, always indicate also the + sign. Preset to 0.</p>
<b>RAX</b>	& ###.##	<p>Reads the offset set for the pressure measurement.</p>



## 5 MODBUS-RTU PROTOCOL

In MODBUS-RTU mode (only models HD9408.3B.1 and HD9408.3B.2), the instrument sends the acquired measurements only if specifically requested by the PC, PLC or data logger.

The protocol is available with RS485 and RS422 serial connections.

### 5.1 MEASUREMENTS READING

In MODBUS mode, the function code 04h (Read Input Registers) allows reading the values measured by the instrument. Table 5.1.1 lists the MODBUS input registers available:

**TAB. 5.1.1: MODBUS Input Registers**

Register number	Register address	Quantity	Format
1,2	0,1	Temperature in the set unit of measurement [x100]	16-bit integer
3,4	2,3	Atmospheric pressure in the set unit of measurement. See table 4.3.1 for the position of the decimal point.	16-bit integer

The measurements are signed 32-bit integer values. To read a measurement, two consecutive 16-bit registers must be accessed. The register with lower address (for example register number 3 for the atmospheric pressure) contains the most significant bytes.

*Note:* the accuracy of the temperature measurement is  $\pm 1$  °C. The resolution is hundredths.

### 5.2 SETTING THE MODBUS PARAMETERS

To set the Modbus address and the Modbus communication parameters, if different from the factory default values, use the serial commands **CMA** (sets the address), **CMB** (sets the Baud Rate), **CMP** (sets the parity and the stop bits) and **CMW** (sets the receiving mode) of the Delta OHM proprietary protocol (see the parameters setting procedure in paragraph 4.5).

Alternatively, the parameters can be set directly with Modbus commands by writing their values in the Holding Registers (see table 5.2.1) with the function code 06h (Write Single Register) or 10h (Write Multiple Registers).

To check if the last writing operation has been completed successfully, verify that the Holding Register number 1 (address 0) contains the value 0, by using the 03h function code (Read Holding Registers).

**The 06h and 10h writing functions change only the value of the parameters in the RAM memory, the change is therefore cancelled in case of power supply failure in the instrument.** To make the change permanent, write the hexadecimal value FF00 in the Coil Register number 3 (address 2) by using the 05h function code (Write Single Coil). The command 05h must be sent within 10 seconds from the last 06h or 10h command.

To check if the permanent storage has been completed successfully, verify that the Holding Register number 2 (address 1) contains the value 0, by using the 03h function code (Read Holding Registers).

**TAB. 5.2.1: MODBUS Holding Registers**

Register number	Register address	Datum	Format
1	0	Indicator of the correct execution of the last writing command. If <b>0</b> , the command has been executed correctly. If <b>1</b> , command execution errors occurred.	16-bit integer
2	1	Indicator of the correct permanent storage of the parameters. If <b>0</b> , the parameters have stored correctly. If <b>1</b> , storage errors occurred.	16-bit integer
3	2	Error register (see paragraph 5.4)	16-bit integer
7	6	Configuration register (see paragraph 5.3)	16-bit integer
101	100	Modbus address (from 1 to 247). Preset to 1.	16-bit integer
102	101	Modbus Baud Rate. Acceptable values: 0 and 1. If <b>0</b> , the Baud Rate is 9600. If <b>1</b> , the Baud Rate is 19200. Preset to 1 ⇒ 19200	16-bit integer
103	102	Modbus transmission mode. Acceptable values: from 0 to 5. <b>0</b> ⇒ 8N1, <b>1</b> ⇒ 8N2, <b>2</b> ⇒ 8E1, <b>3</b> ⇒ 8E2 <b>4</b> ⇒ 8O1, n= <b>5</b> ⇒ 8O2 Preset to 2 ⇒ 8E1 Note: N=no parity, E=even parity, O=odd parity	16-bit integer
104	103	Receiving mode after the Modbus transmission. Acceptable values: 0 and 1. <b>0</b> ⇒ Violates the protocol and goes immediately in reception mode after the transmission <b>1</b> ⇒ Respects the protocol and waits for 3.5 characters after the transmission Preset to 1 ⇒ Respects the protocol.	16-bit integer

**TAB. 5.2.2: MODBUS Coils**

Register number	Register address	Datum
3	2	Permanent storage of the parameters.

### 5.3 CONFIGURATION REGISTER

The configuration register (Holding Register number 7) allows applying an offset to the pressure measurement and setting the pressure and temperature units of measurement. The meaning of the register bits is shown in table 5.3.1.

**TAB. 5.3.1: configuration register**

Bit	Description
0...10	Offset, expressed in hundredths of hPa, added to the measured pressure value. Must be between -1000 (= -10.00 hPa) and +1000 (= +10.00 hPa). Preset to 0. Bit 10 indicates the sign of the value. Bits 0...9 indicate the absolute value expressed in 2's complement (bit 0 is the less significant): 3E8h ⇒ +1000, 7FFh ⇒ -1, 418h ⇒ -1000
11...14	Pressure unit of measurement read with the MODBUS protocol: <b>0h</b> ⇒ Torr, <b>1h</b> ⇒ Pa, <b>2h</b> ⇒ hPa, <b>3h</b> ⇒ kPa, <b>4h</b> ⇒ mbar, <b>5h</b> ⇒ psi, <b>6h</b> ⇒ kg/cm <sup>2</sup> , <b>7h</b> ⇒ mmH <sub>2</sub> O, <b>8h</b> ⇒ mmHg, <b>9h</b> ⇒ inHg, <b>Ah</b> ⇒ atm, <b>Bh</b> ⇒ bar, <b>Ch</b> ⇒ ftH <sub>2</sub> O Bit 11 is the less significant. Preset to 2 ⇒ hPa
15	Temperature unit of measurement read with the MODBUS protocol: <b>0</b> ⇒ °C, <b>1</b> ⇒ °F Preset to 0 ⇒ °C

### 5.4 ERROR REGISTER

The function code 03h (Read Holding Registers) allows reading the 16-bit register number 3 (address 2) containing information on the possible error status of the transmitter.

The bits of the register indicate the error condition according to the correspondence shown in table 5.4.1.

**TAB. 5.4.1: error register**

Bit	Description
0	General error
1,2	Error in the values of the configuration parameters in memory
3	Error in the program memory
4	The power supply of the instrument is outside the allowed limits
5	Communication error
6	Error executing the measurement
7	Check of the instrument calibration is necessary
8	The device has executed a reset
9	Timeout of the temperature measurement
10	Error in the management of the analog output
11	Invalid data format
12...15	Not used

The register is reset after the reading. If the error condition persists, the corresponding bit is restored.

## 6 NMEA PROTOCOL

In NMEA mode (only models HD9408.3B.1 and HD9408.3B.2), the instrument sends automatically the acquired measurements at regular intervals. The interval is factory-set to 1 second and can be configured within 1 and 3600 seconds. To change the interval you should send the serial command **CPD** of the Delta OHM proprietary protocol (see the parameters setting procedure in paragraph 4.5).

The protocol is available with RS232, RS485 and RS422 serial connections. Communication parameters should be set in the PC or data logger as follows:

- Baud rate = 4800
- Data bits = 8
- Parity = Nessuna
- Stop bits = 1

The instrument is compatible with NMEA 0183 V4.00 protocol.

The protocol establishes that data are sent in the following format:

**\$PXDR,<Data>\*<hh><CR><LF>**

with:

- <Data> = values measured by the instrument, separated by commas
- <hh> = checksum, consisting in two hexadecimal characters
- <CR> = character ASCII *Carriage Return*
- <LF> = character ASCII *Line Feed*

The checksum is calculated by performing the exclusive OR of all characters ranging within **\$** and **\*** symbols. The 4 most significant bits and the 4 less significant bits of the result are converted in hexadecimal. The hexadecimal value corresponding to the most significant bits is transmitted as the first.

The instrument regularly sends the following string:

**\$PXDR,P,xxxxxx,P,x.xxxxx,B,xx.xx,C\*hh<CR><LF>**

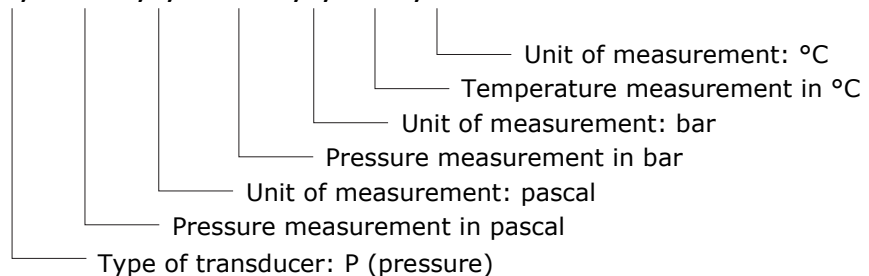

### EXAMPLE

Suppose that there are the following environmental conditions:

- Atmospheric pressure = 1023.64 hPa
- Temperature = 26.28 °C

The strings sent by the instrument are:

**\$PXDR,P,102364,P,1.02364,B,26.28,C\*3D<CR><LF>**

*Note:* the accuracy of the temperature measurement is  $\pm 1$  °C.

For additional information regarding the protocol, visit the site "[www.nmea.org](http://www.nmea.org)".

## 7 SDI-12 PROTOCOL

The **HD9408.3B.3** transmitter is equipped with an SDI-12 communication interface compliant with the version 1.3 of the protocol, which allows the connection to SDI-12 sensors networks.

The communication parameters of the protocol are:

- Baud rate = 1200
- Data bits = 7
- Parity = Even
- Stop bits = 1

Communication with the instrument is performed by sending a command in the following format:

**< Address >< Command >!**

with: <Address> = address of the instrument the command is sent to  
 <Command> = type of operation requested to the instrument

The instrument reply is as follows:

**< Address ><Data><CR><LF>**

with: <Address> = address of the replying instrument  
 <Data> = information sent by the instrument  
 <CR> = ASCII character *Carriage Return*  
 <LF> = ASCII character *Line Feed*

The transmitter comes with a factory address preset to 0. The address can be modified by using the proper SDI-12 command reported in the following table.

The table below shows the available SDI-12 commands. To comply with the SDI-12 standard, the instrument address is indicated in the table with the letter **a**.

**TAB. 7.1: SDI-12 commands**

Command	Instrument reply	Description
<b>a!</b>	a<CR><LF>	Checks for the presence of the instrument.
<b>aI!</b>	allccccccmmmmmmvvvsssssss<CR><LF> where: a = address of the instrument (1 character) ll = compatible SDI-12 version (2 characters) ccccccc = manufacturer (8 characters) mmmmmm = instrument model (6 characters) vvv = firmware version (3 characters) sssssss = serial number (8 characters)  ⇒ Example of reply: 013DeltaOhm9408T4A0113201518  with: 0 = address of the instrument 13 = compatible SDI-12 version 1.3 DeltaOhm = name of manufacturer 9408T4 = instrument model A01 = firmware version 13201518 = serial number	Request for instrument information.

Command	Instrument reply	Description
<b>aAb!</b> where: b =new address	b<CR><LF>  Note: if character b is not an acceptable address, the instrument answers with a in the place of b.	Change of instrument address.
<b>?!</b>	a<CR><LF>	Request for instrument address. If more than a sensor is connected to the bus, a conflict will occur.
<b>TYPE M COMMANDS (START MEASUREMENT)</b>		
<b>Atmospheric pressure and temperature</b>		
<b>aM!</b>	atttn<CR><LF> with:ttt = number of seconds necessary for the instrument to make the measure available (3 characters) ttt is fixed to 002 n = number of detected variables (1 character) n is fixed to 2	Request for performing the measurement of atmospheric pressure and temperature.
<b>aD0!</b>	a+xxxxx+xxx<CR><LF> ⇒ Example of response: 0+1020.1+28.3 The instrument with address 0 measures 1020.1 in the set pressure unit of measurement and 28.3 in the set temperature unit of measurement	Reads the measurements of atmospheric pressure and temperature in the set units of measurement. (accuracy of temperature measurement: ± 1 °C)
<b>Atmospheric pressure in mbar</b>		
<b>aM1!</b>	atttn<CR><LF> with:ttt = number of seconds necessary for the instrument to make the measure available (3 characters) ttt is fixed to 002 n = number of detected variables (1 character) n is fixed to 1	Request for performing the measurement of atmospheric pressure in mbar.
<b>aD0!</b>	a+xxxx.x<CR><LF> ⇒ Example of response: 0+1020.1 The instrument with address 0 measures 1020.1 mbar	Reads the measurements of atmospheric pressure in mbar.
<b>Atmospheric pressure in psi</b>		
<b>aM2!</b>	atttn<CR><LF> with:ttt = number of seconds necessary for the instrument to make the measure available (3 characters) ttt is fixed to 002 n = number of detected variables (1 character) n is fixed to 1	Request for performing the measurement of atmospheric pressure in psi.
<b>aD0!</b>	a+xx.xxxx<CR><LF> ⇒ Example of response: 0+14.7953 The instrument with address 0 measures 14.7953 PSI	Reads the measurements of atmospheric pressure in psi.

Command	Instrument reply	Description
<b>Atmospheric pressure unit of measurement</b>		
<b>aM3!</b>	atttn<CR><LF> with: ttt = number of seconds necessary for the instrument to make the info available (3 characters). ttt is fixed to 000. n = number of detected variables (1 character) n is fixed to 1	Request of the atmospheric pressure unit of measurement.
<b>aD0!</b>	a+nn<CR><LF> with: nn = index of the unit of measurement nn = 00 ⇒ Torr      nn = 07 ⇒ mmH <sub>2</sub> O nn = 01 ⇒ Pa      nn = 08 ⇒ mmHg nn = 02 ⇒ hPa      nn = 09 ⇒ inHg nn = 03 ⇒ kPa      nn = 10 ⇒ atm nn = 04 ⇒ mbar      nn = 11 ⇒ bar nn = 05 ⇒ psi      nn = 12 ⇒ ftH <sub>2</sub> O nn = 06 ⇒ kg/cm <sup>2</sup>	Reads the atmospheric pressure unit of measurement.
<b>Temperature unit of measurement</b>		
<b>aM4!</b>	atttn<CR><LF> with: ttt = number of seconds necessary for the instrument to make the info available (3 characters). ttt is fixed to 000. n = number of detected variables (1 character) n is fixed to 1	Request of the temperature unit of measurement.
<b>aD0!</b>	a+n<CR><LF> with: n = index of the unit of measurement n = 0 ⇒ °C n = 1 ⇒ °F	Reads the temperature unit of measurement.
<b>TYPE C COMMANDS (START CONCURRENT MEASUREMENT)</b>		
<b>aC!</b>	atttn<CR><LF> with: ttt = number of seconds necessary for the instrument to make the measure available (3 characters) ttt is fixed to 002 n = number of detected variables (1 character) n is fixed to 2	Request for performing the measurement of atmospheric pressure and temperature.
<b>aD0!</b>	a+xxxxx+xxx<CR><LF> ⇒ Example of response: 0+1020.1+28.3 The instrument with address 0 measures 1020.1 in the set pressure unit of measurement and 28.3 in the set temperature unit of measurement	Reads the measurements of atmospheric pressure and temperature in the set units of measurement. (accuracy of temperature measurement: ± 1 °C)

Command	Instrument reply	Description
<b>TYPE X COMMANDS (EXTENDED COMMANDS)</b>		
<b>aXSG0!</b>	aModel <CR><LF>	Request of the instrument model.
<b>aXSG2!</b>	aSN=number <CR><LF>	Request of the instrument serial number.
<b>aXSG3!</b>	aFirm.Ver.=version <CR><LF>	Request of the firmware version.
<b>aXSG4!</b>	aAAAA/MM/GG <CR><LF>	Request of the firmware date.
<b>aXSCAL USER ON!</b>	a&USER ENABLED!<CR><LF>	Enables the configuration commands.
<b>aXSCPUn!</b>	a& <CR><LF>	Sets the atmospheric pressure unit of measurement: n=0 ⇒ Torr, n=1 ⇒ Pa, n=2 ⇒ hPa, n=3 ⇒ kPa n=4 ⇒ mbar, n=5 ⇒ psi, n=6 ⇒ kg/cm <sup>2</sup> , n=7 ⇒ mmH <sub>2</sub> O n=8 ⇒ mmHg, n=9 ⇒ inHg, n=A ⇒ atm, n=B ⇒ bar n=C ⇒ ftH <sub>2</sub> O Preset to 2 ⇒ hPa
<b>aXSRAU!</b>	a&n <CR><LF>	Reads the set atmospheric pressure unit of measurement (see the command aXSCPUn! for the unit of measurement corresponding to the value n).
<b>aXSCAXnnnn!</b>	a& <CR><LF>	Adds the offset nnnn, in hundredths of hPa, to the measured pressure value. nnnn must be between -1000 (= -10,00 hPa) and +1000 (= +10,00 hPa). For positive values, always indicate also the + sign. Preset to 0.
<b>aXSRAx!</b>	a&nnnn <CR><LF>	Reads the offset set for the pressure measurement.
<b>aXSCPTx!</b>	a& <CR><LF>	Sets the temperature unit of measurement: x=C ⇒ °C, x=F ⇒ °F Preset to C ⇒ °C
<b>aXSRAT!</b>	a&x <CR><LF>	Reads the set temperature unit of measurement (see the command aXSCPTx! for the unit of measurement corresponding to the value x).



The configuration commands aXSCPU!, aXSCAXnnnn! and aSXCPTx! require that the configuration mode is activated by sending the command aXSCAL USER ON!. The configuration mode is disabled if no configuration commands are sent for 5 minutes.

The transmitter does not support the commands aC1!...aC9! (Additional Concurrent Measurement) and the commands aR0!...aR9! (Continuous Measurements).

In addition to the above-mentioned commands, the transmitter also implements the corresponding commands with CRC, that require to add a 3-character CRC code at the end of the reply before <CR><LF>. The format of these commands is obtained from the previous by adding the letter C: aMC!, aM1C!, aM2C!, aM3C!, aM4C!, aCC!.

For more information about the protocol, visit the website "[www.sdi-12.org](http://www.sdi-12.org)".

## 8 TECHNICAL SPECIFICATIONS

<b>Sensor</b>	High accuracy piezoresistive
<b>Measuring range</b>	0...1350 hPa for the digital outputs 500...1200 hPa for the analog outputs
<b>Resolution</b>	0.01 hPa
<b>Accuracy</b>	± 0.1 hPa (500...1200 hPa) / ± 0.2 hPa (remaining range) @ 23 °C ± 0.3 hPa (500...1200 hPa) / ± 0.4 hPa (remaining range) in the entire temperature operating range -40...+85 °C
<b>Measuring units available with Modbus and SDI-12 protocols</b>	Pa, hPa, kPa, mbar, bar, atm, psi, mmHg, inHg, mmH <sub>2</sub> O, ftH <sub>2</sub> O, kg/cm <sup>2</sup> , Torr.
<b>Long term stability @ 25 °C</b>	0.25 hPa/year
<b>Output signal</b>	<ul style="list-style-type: none"> <li>• <b>RS485</b> digital output with standard MODBUS-RTU and NMEA protocols and Delta OHM proprietary protocol (only HD9408.3B.1 and HD9408.3B.2)</li> <li>• <b>RS422</b> digital output with standard MODBUS-RTU and NMEA protocols and Delta OHM proprietary protocols (only HD9408.3B.1 and HD9408.3B.2)</li> <li>• <b>RS232</b> digital output with standard NMEA protocol and Delta OHM proprietary protocol (only HD9408.3B.1 and HD9408.3B.2)</li> <li>• <b>SDI-12</b> digital output (only HD9408.3B.3)</li> <li>• <b>Analog voltage</b> output 0...5 / 1...5 V (only HD9408.3B.1)</li> <li>• <b>Analog active current</b> output 0...20/4...20 mA (only HD9408.3B.2)</li> </ul>
<b>Warm-up time</b>	2 s approx. from powering
<b>Measuring period</b>	16 ms for HD9408.3B.1 and HD9408.3B.2 (in the HD9408.3B.3, the measurement is made upon user request)
<b>Analog output response time</b>	150 ms to reach 90% of final value with step pressure input (from 600 to 1000 hPa)
<b>Overpressure limit</b>	3 x f.s.
<b>Compatible media</b>	Only dry air and non corrosive gases
<b>Power supply</b>	10...30 Vdc
<b>Absorption</b>	< 10 mA @ 12 Vdc for HD9408.3B.1 and HD9408.3B.2 < 200 µA @ 12 Vdc for HD9408.3B.3 (average consumption between two subsequent measurements)
<b>Pressure connection</b>	Ø 5 mm flexible tube
<b>Electrical connections</b>	M12
<b>Operating conditions</b>	-40...+85 °C / 0...100% RH
<b>Storage temperature</b>	-40...+85 °C
<b>Dimensions</b>	120 x 77 x 33 mm
<b>Housing material</b>	Anticorodal
<b>Protection degree</b>	IP67

**DIMENSIONS (mm):**

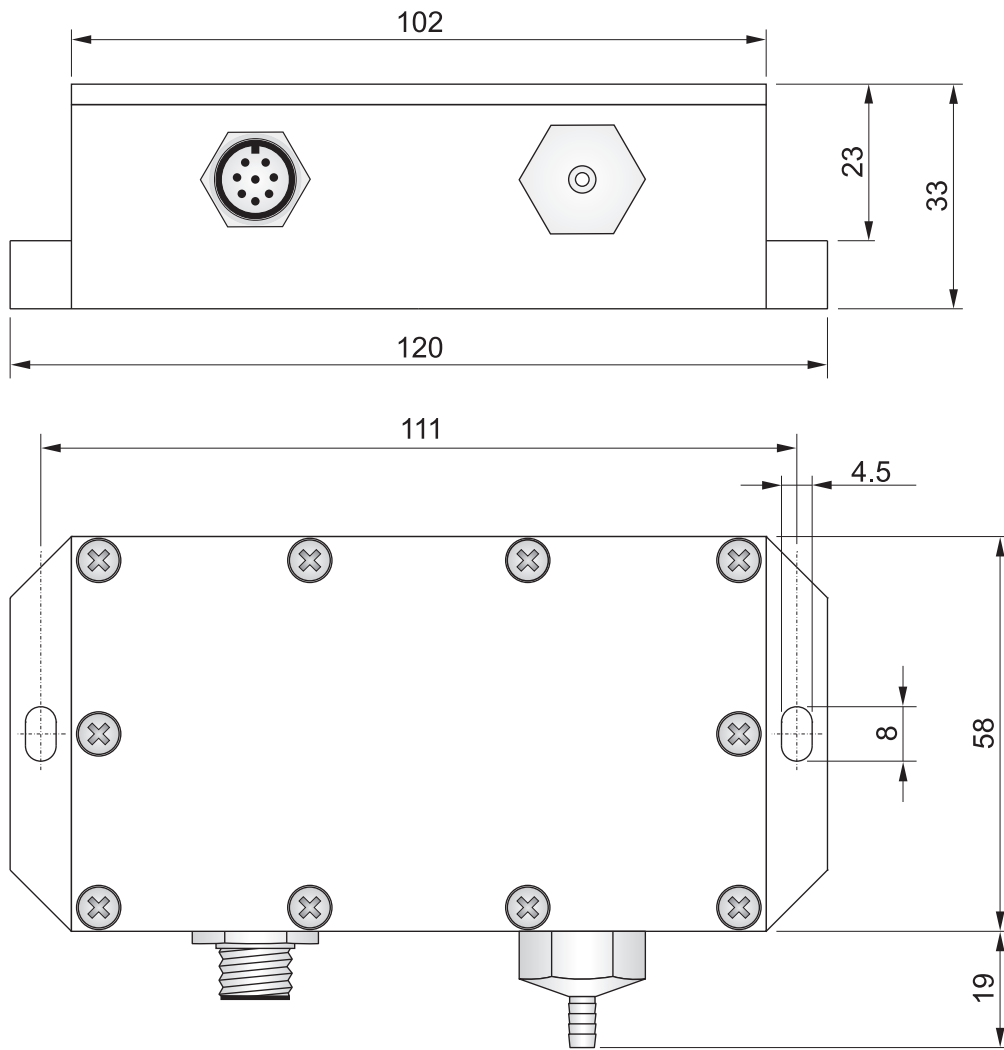

## 9 INSTRUMENT STORAGE

Instrument storage conditions:

- Temperature: -45...+85 °C.
- Humidity: 100%RH.
- In storage, avoid places where:
  - the instrument is exposed to direct sun radiation;
  - the instrument is exposed to a high temperature source;
  - high vibration levels are present;
  - the instrument may be exposed to vapor, salt and/or corrosive gas.

## 10 SAFETY INSTRUCTIONS

### General safety instructions

The instrument has been manufactured and tested in accordance with the safety standard EN61010-1:2010 "Safety requirements for electrical equipment for measurement, control and laboratory use" and has left the factory in perfect safety technical conditions.

The instrument proper operation and operating safety can be ensured only if all standard safety measures as well as the specific measures described in this manual are followed.

The instrument proper operation and operating safety can be ensured only in the climatic conditions specified in this manual.

Do not use the instruments in places where there are:

- Rapid ambient temperature variations that may cause condensation.
- Corrosive or flammable gases.
- Direct vibrations or shocks to the instrument.
- High-intensity electromagnetic fields, static electricity.

If the instrument is moved from a cold environment to a hot one or vice versa, the formation of condensation might cause problems to its operation. In this case you need to wait for the instrument temperature to reach ambient temperature before operation.

### User obligations

The instrument operator shall follow the directives and regulations below that refer to the treatment of dangerous materials:

- EEC directives on workplace safety.
- National law regulations on workplace safety.
- Accident prevention regulations.

## 11 ORDERING CODES

- HD9408.3B.1** Precision barometric transmitter. Measuring range 0...1350 hPa (digital outputs) or 500...1200 hPa (analog output). Accuracy  $\pm 0.1$  hPa @ 23 °C in the range 500...1200 hPa. Configurable voltage output signal 0...5 V or 1...5 V. Digital RS232, RS422 or RS485 output. Standard MODBUS-RTU and NMEA protocols. Power supply 10...30 Vdc. IP 67 housing. Provided with free 8-pole M12 connector. **The cable CP18... with female 8-pole M12 connector has to be ordered separately.**
- HD9408.3B.2** Precision barometric transmitter. Measuring range 0...1350 hPa (digital outputs) or 500...1200 hPa (analog output). Accuracy  $\pm 0.1$  hPa @ 23 °C in the range 500...1200 hPa. Configurable active current 0...20 mA or 4...20 mA output. Digital RS232, RS422 or RS485 output. Standard MODBUS-RTU and NMEA protocols. Power supply 10...30 Vdc. IP 67 housing. Provided with free 8-pole M12 connector. **The cable CP18... with female 8-pole M12 connector has to be ordered separately.**
- HD9408.3B.3** Precision barometric transmitter. Measuring range 0...1350 hPa. Accuracy  $\pm 0.1$  hPa @ 23 °C in the range 500...1200 hPa. SDI-12 digital output. Power supply 10...30 Vdc. IP 67 housing. Provided with free 4-pole M12 connector. **The cable CPM12AA4... with female 4-pole M12 connector has to be ordered separately.**

### Accessories

- CP18.2** Cable with 8-pole M12 connector on one end, open wires on the other side. Length 2 m. For HD9408.3B.1 and HD9408.3B.2 transmitters.
- CP18.5** Cable with 8-pole M12 connector on one end, open wires on the other side. Length 5 m. For HD9408.3B.1 and HD9408.3B.2 transmitters.
- CPM12AA4.2** Cable with 4-pole M12 connector on one end, open wires on the other side. Length 2 m. For HD9408.3B.3 transmitter.
- CPM12AA4.5** Cable with 4-pole M12 connector on one end, open wires on the other side. Length 5 m. For HD9408.3B.3 transmitter.
- RS48** Cable for RS485 connection with built-in USB/RS485 converter. The cable has USB connector for PC and 3 separate wires for the instruments.
- RS52** Serial connection cable with built-in USB/RS232 converter. USB connector for the PC and screw terminals on the instrument side.

**DELTA OHM metrology laboratories LAT N° 124 are ISO/IEC 17025 accredited by ACCREDIA for Temperature, Humidity, Pressure, Photometry / Radiometry, Acoustics and Air Velocity. They can supply calibration certificates for the accredited quantities.**

## Notes

---

**DICHIARAZIONE DI CONFORMITÀ UE  
EU DECLARATION OF CONFORMITY****Delta Ohm S.r.L. a socio unico – Via Marconi 5 – 35030 Caselle di Selvazzano – Padova – ITALY**Documento Nr. / Mese.Anno: **5003 / 07.2019**  
Document-No. / Month.Year :

Si dichiara con la presente, in qualità di produttore e sotto la propria responsabilità esclusiva, che i seguenti prodotti sono conformi ai requisiti di protezione definiti nelle direttive del Consiglio Europeo:

*We declare as manufacturer herewith under our sole responsibility that the following products are in compliance with the protection requirements defined in the European Council directives:*Codice prodotto: **HD9408.3B**  
Product identifier :Descrizione prodotto: **Trasmettitore barometrico**  
Product description : **Barometric transmitter**I prodotti sono conformi alle seguenti Direttive Europee:  
*The products conform to following European Directives:*

Direttive / Directives	
2014/30/EU	Direttiva EMC / EMC Directive
2014/35/EU	Direttiva bassa tensione / Low Voltage Directive
2011/65/EU - 2015/863/EU	RoHS / RoHS

Norme armonizzate applicate o riferimento a specifiche tecniche:  
*Applied harmonized standards or mentioned technical specifications:*

Norme armonizzate / Harmonized standards	
EN 61010-1:2010	Requisiti di sicurezza elettrica / Electrical safety requirements
EN 61326-1:2013	Requisiti EMC / EMC requirements
EN 50581:2012	RoHS / RoHS

Il produttore è responsabile per la dichiarazione rilasciata da:  
*The manufacturer is responsible for the declaration released by:*

Johannes Overhues

Amministratore delegato  
Chief Executive Officer

Caselle di Selvazzano, 19/07/2019

Questa dichiarazione certifica l'accordo con la legislazione armonizzata menzionata, non costituisce tuttavia garanzia delle caratteristiche.

*This declaration certifies the agreement with the harmonization legislation mentioned, contained however no warranty of characteristics.*

# GUARANTEE



Member of GHM GROUP

## TERMS OF GUARANTEE

All DELTA OHM instruments are subject to accurate testing, and are guaranteed for 24 months from the date of purchase. DELTA OHM will repair or replace free of charge the parts that, within the warranty period, shall be deemed non efficient according to its own judgement. Complete replacement is excluded and no damage claims are accepted. The DELTA OHM guarantee only covers instrument repair. The guarantee is void in case of incidental breakage during transport, negligence, misuse, connection to a different voltage than that required for the appliance by the operator. Finally, a product repaired or tampered by unauthorized third parties is excluded from the guarantee. The instrument shall be returned **FREE OF SHIPMENT CHARGES** to your dealer. The jurisdiction of Padua applies in any dispute.



The electrical and electronic equipment marked with this symbol cannot be disposed of in public landfills. According to the Directive 2011/65/EU, the european users of electrical and electronic equipment can return it to the dealer or manufacturer upon purchase of a new one. The illegal disposal of electrical and electronic equipment is punished with an administrative fine.

This guarantee must be sent together with the instrument to our service centre.

**IMPORTANT:** Guarantee is valid only if coupon has been correctly filled in all details.

**Instrument Code: HD9408.3B**

Serial Number \_\_\_\_\_

## RENEWALS

Date \_\_\_\_\_

Date \_\_\_\_\_

Inspector \_\_\_\_\_

Inspector \_\_\_\_\_

Date \_\_\_\_\_

Date \_\_\_\_\_

Inspector \_\_\_\_\_

Inspector \_\_\_\_\_

Date \_\_\_\_\_

Date \_\_\_\_\_

Inspector \_\_\_\_\_

Inspector \_\_\_\_\_





The quality level of our instruments is the result of the constant development of the product. This may produce some differences between the information written in this manual and the instrument you have purchased. We cannot completely exclude the possibility of errors in the manual, for which we apologize.

The data, images and descriptions included in this manual cannot be legally asserted. We reserve the right to make changes and corrections with no prior notice.

**V1.6**  
**16/11/2020**